

Reliable Shut-off Performance

Increased safety through seat leakage monitoring

samson

Integrated
EXPERTplus
valve diagnostics

24h

- Option for Types 3730-2, 3730-3, 3730-5 and 3730-6 Positioners
- In-service seat leakage monitoring with alarm
- Statistical seat leakage analysis across the entire operating cycle
- Diagnostics with classification according to NAMUR Recommendation NE 107
- Simple start-up and operation
- No additional power supply required



HART
COMMUNICATION PROTOCOL

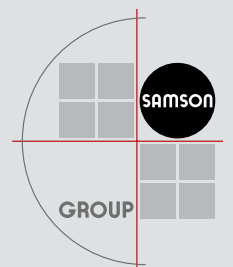
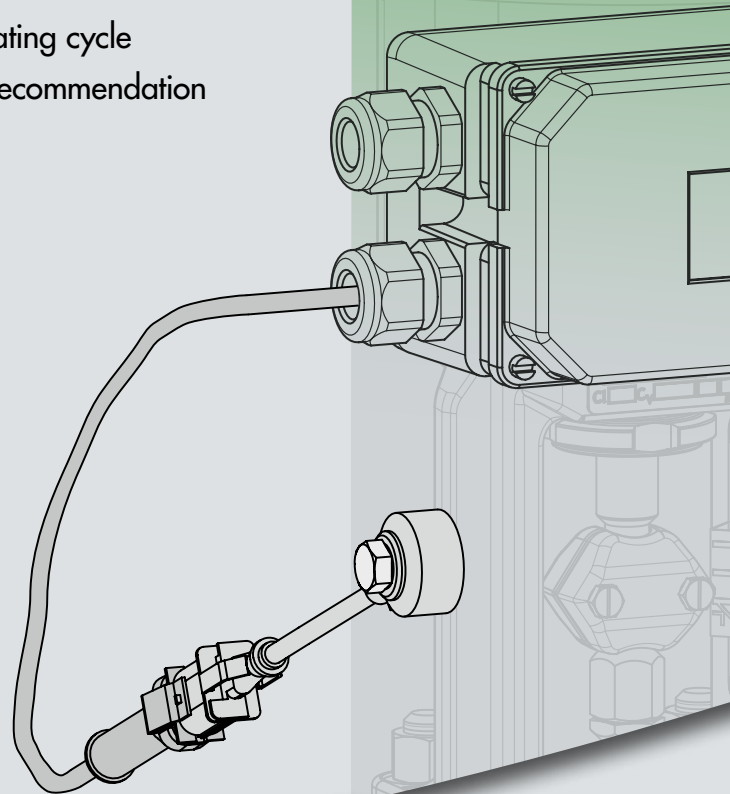

Further information

Installation and operation

- Mounted on the valve yoke (preferably on NAMUR rib)
- Powered by positioner's input signal
- Assessment using the free EXPERTplus valve diagnostics integrated into the positioner
- Configuration using the free TROVIS-VIEW software
- Device integration, e.g. using EDDL or FDT/DTM

Statistical seat leakage analysis during operation

- Automatic monitoring to detect short-term changes in the shut-off performance
- Automatic long-term sound level monitoring
- Histogram plotting the sound level over the entire operating range

Seat leakage monitoring with alarm

- Max. three user-defined alarm limits
- Diagnostics with classification according to NAMUR Recommendation NE 107

Further technical data

- Temperature range (mounting surface): -40 to 130 °C
- Suitable for hazardous areas

